



REINFORCED BELLOWS VACUUM CUPS WITH SUPPORTS

3D drawings are available on vuototecnica.net

The cups described on these pages share the same features with the previously described bellows cups, only these have larger dimensions that allow them to lift much heavier loads; moreover, their anodised aluminium supports also have a central threaded hole for their fastening to the automation. The larger ones also have an additional side hole for vacuum connection. The difference is that these supports are provided with a disc instead of with a pin. These cups can be cold fitted onto their supports without any adhesives.

To replace, simply request the single vacuum cup indicated in the table in the desired compound.

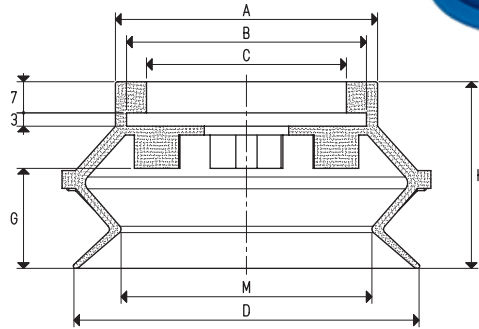

VACUUM CUP

Item	Force Kg	Compounds available	Volume cm ³	A Ø	B Ø	C Ø	D Ø	G	H	M Ø	Bellows stroke mm
01 75 42 *	11.93	Ⓐ Ⓝ Ⓢ	89.4	59	54	45	78	22.5	42	56	22.5

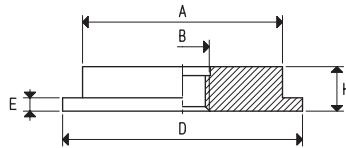

SUPPORTS

Item	A Ø	B Ø	D Ø	E	H	Support material	For vacuum cup item	Weight g
00 08 126	45	M12	54	3	10	aluminium	01 75 42	45.5
00 08 465	45	G1/4"	54	3	10	aluminium	01 75 42	41.5
00 08 193	45	G3/8"	54	3	10	aluminium	01 75 42	41.5
00 08 143	45	G1/2"	54	3	10	aluminium	01 75 42	41.5

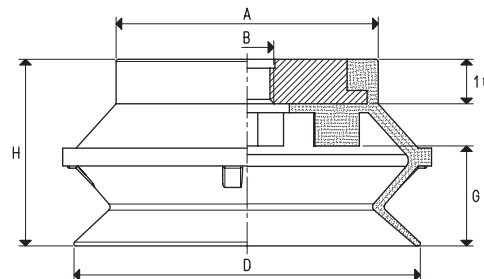

VACUUM CUPS WITH SUPPORT

Item	Force Kg	Compounds available	A Ø	B Ø	D Ø	G	H	Vacuum cup item	Support item	Weight g
08 75 42 *	11.93	Ⓐ Ⓝ Ⓢ	59	M12	78	22.5	42	01 75 42	00 08 126	94.8
08 75 42 1/4" *	11.93	Ⓐ Ⓝ Ⓢ	59	G1/4"	78	22.5	42	01 75 42	00 08 465	90.8
08 75 42 3/8" *	11.93	Ⓐ Ⓝ Ⓢ	59	G3/8"	78	22.5	42	01 75 42	00 08 193	90.8
08 75 42 1/2" *	11.93	Ⓐ Ⓝ Ⓢ	59	G1/2"	78	22.5	42	01 75 42	00 08 143	90.8

* Complete the code indicating the compound: Ⓐ = oil-resistant rubber; Ⓝ = para rubber; Ⓢ = silicone

Note: Cups in special compounds, listed on page 31 can be provided upon specific request in minimum quantities to be defined in the order.

The force of the vacuum cups indicated in the table represents 1/3 of the value of the theoretical force calculated at a level of vacuum of -75 KPa and a factor of safety 3.

Transformation ratio: N (newton) = Kg x 9.81 (force of gravity)

$$\text{inch} = \frac{\text{mm}}{25.4}; \text{pounds} = \frac{\text{g}}{453.6} = \frac{\text{Kg}}{0.4536}$$

Adapters for GAS - NPT threading available on page 1.134

REINFORCED BELLOWS VACUUM CUPS WITH SUPPORTS

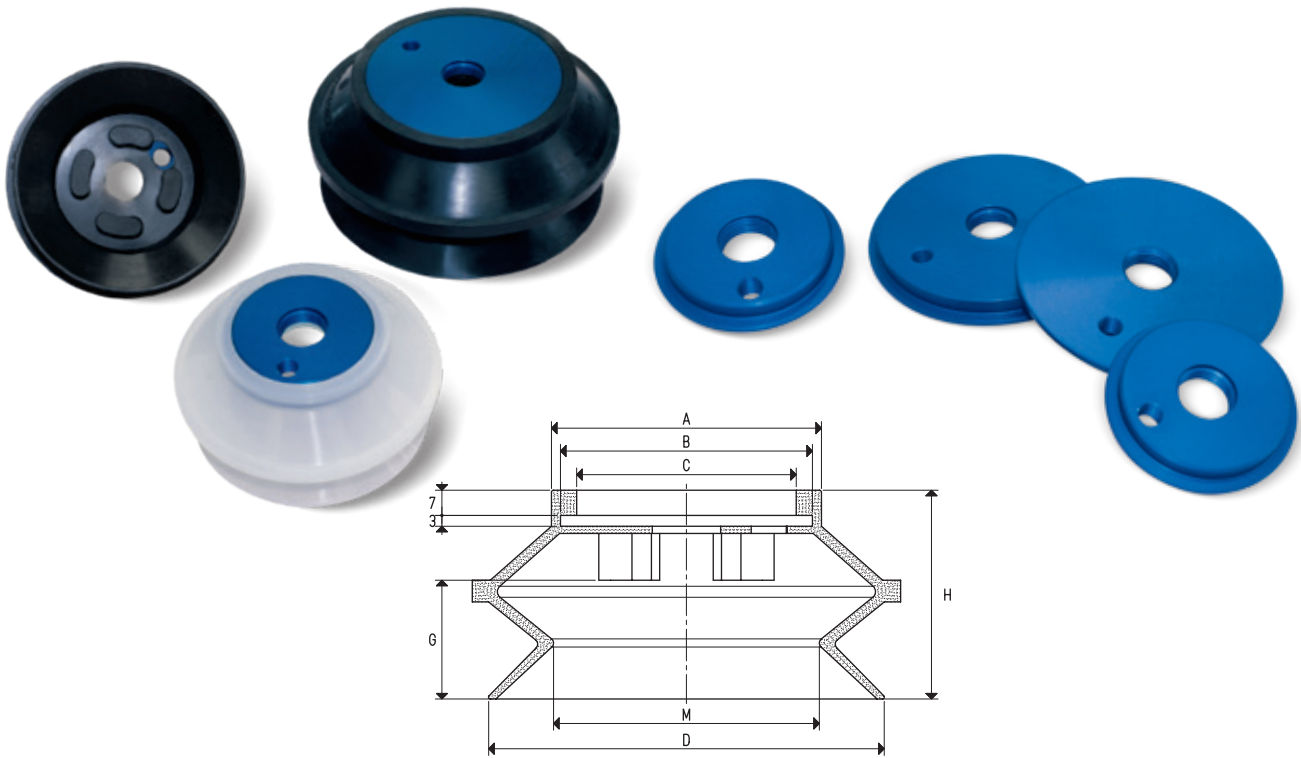

VACUUM CUPS

Item	Force Kg	Compounds available	Volume cm ³	A Ø	B Ø	C Ø	D Ø	G	H	M Ø	Bellows stroke mm
01 110 58 *	23.70		281.9	75	70	61	110	33	58	74	33
01 150 74 *	45.00		726.1	112	107	98	150	49	74	103	49

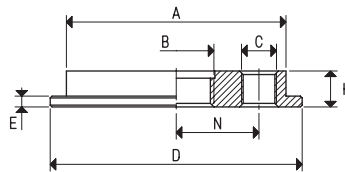

SUPPORTS

Item	A Ø	B Ø	C Ø	D Ø	E	N	H	Support material	For vacuum cup item	Weight g
00 08 162	61	G1/2"	G1/8"	70	3	23	10	aluminium	01 110 58	78.9
00 08 163	98	G1/2"	G1/8"	107	3	35	10	aluminium	01 150 74	211.8

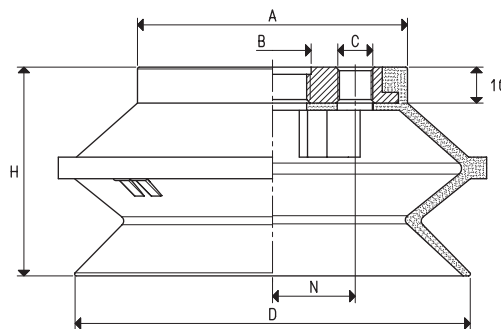

VACUUM CUPS WITH SUPPORT

Item	Force Kg	Compounds available	A Ø	B Ø	C Ø	D Ø	H	N	Vacuum cup item	Support item	Weight g
08 110 58 *	23.70		75	G1/2"	G1/8"	110	58	23	01 110 58	00 08 162	190.7
08 150 74 *	45.00		112	G1/2"	G1/8"	150	74	35	01 150 74	00 08 163	458.7

* Complete the code indicating the compound: = oil-resistant rubber; = para rubber; = silicone

Note: Cups in special compounds, listed on page 31 can be provided upon specific request in minimum quantities to be defined in the order.

The force of the vacuum cups indicated in the table represents 1/3 of the value of the theoretical force calculated at a level of vacuum of -75 KPa and a factor of safety 3.

Transformation ratio: N (newton) = Kg x 9.81 (force of gravity) inch = $\frac{\text{mm}}{25.4}$; pounds = $\frac{\text{g}}{453.6} = \frac{\text{Kg}}{0.4536}$ Adapters for GAS - NPT threading available on page 1.134